



# DRS402

## 4" High Performance Coaxial

### CARACTERISTICAS

- Nominal 50 Watts
- Dinámico de 200 Watts
- Tweeter con Domo de Seda
- Bobina de 1" KSV
- Cono de Fibra de Vidrio
- Amortiguador de Goma
- Magneto de Oxido Ferroso
- Canasta de Acero Estampado
- Parrilla Incluida
- Frecuencia de Trabajo: 42Hz – 20KHz
- Sensibilidad: 92dB

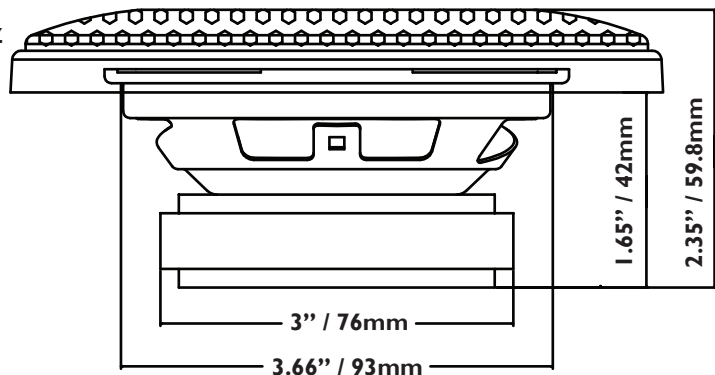
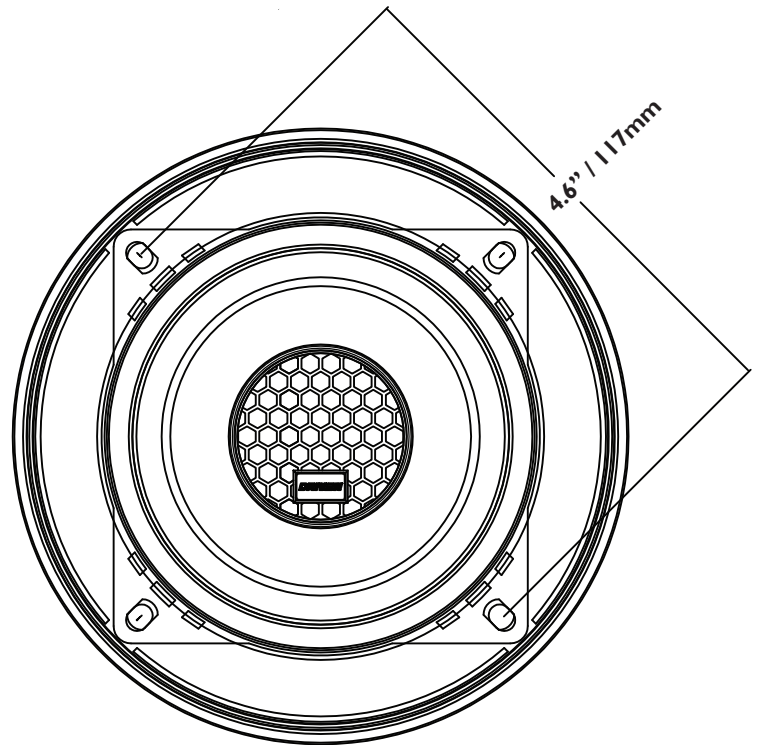



# DRS402

## 4" High Performance Coaxial

### FEATURES

- Nominal 50 watts
- Dynamic 200 watts
- Silk Dome Tweeter
- 1" KSV Voice Coil
- Glass Fiber Cone
- Rubber Surround
- Ferric Oxide Magnet
- Stamped Steel Basket
- Grill included
- Frequency Response: 42Hz – 20KHz
- Sensitivity: 92dB

